

Community

Q-44 FIX

Design: STUDIO OMEGA

 tests UNI EN 15373 livello 3
 tests EN 15373 3rd level standards
 tests EN 15373 3° niveau



Panca per l'attesa appartenente alla famiglia Q-44 di cui mantiene il design e le finiture. È composta da sedile e schienale fissati a una struttura metallica dedicata, realizzata in lamiera d'acciaio tagliata a laser, formando un corpo seduta unico. La seduta viene poi fissata alla trave tramite apposite piastre metalliche di fissaggio. La serie è proposta in quattro varianti: "PP" con sedile e schienale in Polipropilene in 8 colori anche in versione ignifuga CL1, più 1 colore "GREEN" in CL2; "IMPP" con sedile imbottito e schienale in Polipropilene in 8 colori, più 1 colore "GREEN" in CL2; "IM" con sedile e schienale completamente tappezzati; "W" con sedile e schienale in faggio multistrato, proposta di serie con finitura naturale (F), sbiancata (FB). Finiture della parte strutturale metallica: colore nero (N), grigio alluminio (VA) o in colore bianco (BI10).

Q-44 Fix on beam is part of the wide Q-44 family, matching the same design and finishing. The metal bearing seat frame is made of steel sheet duly cutted by means of laser, than bended in order to have a strong support, forming one unit with seat and backrest. The seat is fitted together with the horizontal beam by means of steel brackets and specific screws. The series is suggested with the seat in four variants: "PP" with seat and backrest in Polypropylene, "IMPP" with upholstered seat and backrest in Polypropylene, "IM" with upholstered seat and backrest in Polypropylene, "W" with seat and backrest in beechwood with natural finishing F as standard, or FB bleached finishing as option. The metal frame of seat and beam and legs is available only in black (N) or grey aluminum (VA) colour.

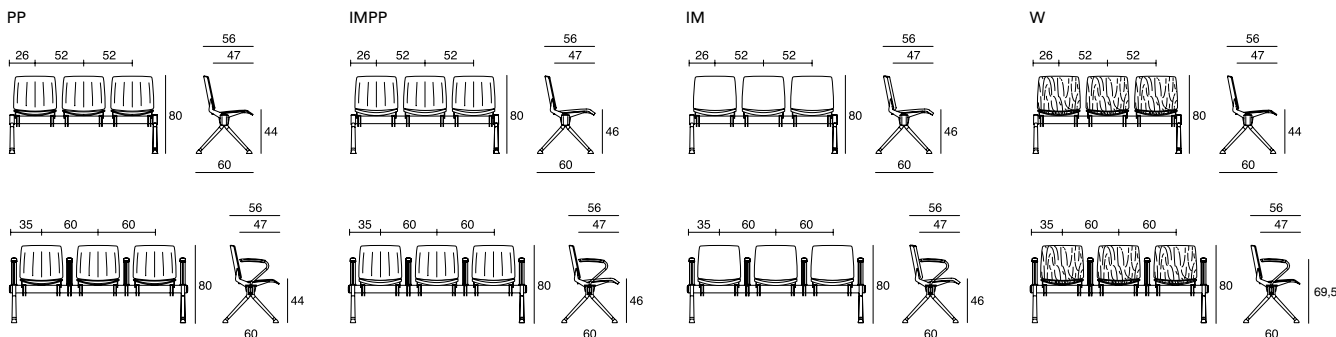
Banc pour salle d'attente appartenant à la famille Q-44 dont il conserve le design et les finitions. Il se compose d'une assise et d'un dossier fixés sur une structure métallique dédiée, en tôle d'acier découpée au laser, formant un corps d'assise unique. Le siège est ensuite fixé à la poutre à l'aide de plaques de fixation métalliques spéciales. La série est disponible en quatre variantes: "PP" avec assise et dossier en Polypropylène en 8 couleurs également dans la version ignifuge CL1, plus 1 couleur "GREEN" en CL2; "IMPP" avec assise et dossier rembourrés en polypropylène en 8 couleurs, plus 1 couleur "GREEN" en CL2; "IM" avec siège et dossier entièrement rembourrés; "W" avec assise et dossier en contreplaqué de hêtre, proposition standard avec finition naturelle (F), blanchie (FB). Finition de la partie structurale métallique: noir (N), gris aluminium (VA) ou blanc (BI10).

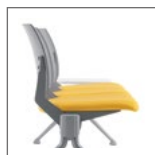

STRUTTURA | FRAME | STRUCTURE



Struttura della seduta realizzata in lamiera d'acciaio spessore 3 mm piegata e sagomata. La struttura della sedia è proposta di serie in colore nero (N), abbinata alle gambe aventi finitura (N) e (CR), mentre è in colore grigio alluminio (VA) o bianco (BI10) con gambe stesso colore.

Seat frame made in steel sheet 3 mm thick duly bended and shaped. The black colour finishing (N) is matched as standard with black colour (N) or (CR) chrome finishing legs, while in grey aluminium (VA) or white (BI10) seat finishing legs have the same colour.

Structure du siège et tôle d'acier épaisseur 3 mm pliée et galbée. Quand le siège est proposé en finition noire (N) est couplée au jambages même en noir ou bien (CR) chromés, tandis que la structure du siège est en coloris gris aluminium (VA) or white (BI10) le jambage est dans la même finition.



Piedino regolabile di 1 cm.
1 cm range height adjustable glide.
Patin réglable de 1 cm.

STRUTTURA SEDUTA | SEAT FRAME | STRUCTURE ASSISE



Trave in profilato d'acciaio a sezione rettangolare da 80x40 mm, in colore nero con gamba finitura (N), trave grigio alluminio con gamba (VA) o bianca con gamba (BI10).

80x40 mm beam for bench in rectangular section steel profile, in black colour with leg finishing (N), grey aluminium beam with leg (VA) or blanc with leg (BI10).

Poutre en profilé d'acier à section rectangulaire de 80x40 mm, en coloris noir avec finition jambage (N), poutre gris aluminium avec jambage (VA) ou blanc avec jambage (BI10).

GAMBA PER PANCA | LEG FOR BENCH | JAMBAGE POUR BANQUETTE



Realizzata in tubo d'acciaio Ø 33 mm, sagomato e schiacciato fino a raggiungere un ovale nella parte terminale. Finitura in colore nero (N), cromata (CR), bianca (BI10) o in colore grigio alluminio (VA), piedini regolabili. Ø 33 mm round steel tube, flattened until oval. Finishing black colour (N), chrome (CR), white (BI10) or grey aluminium colour (VA), adjustable glides.

Réalisé en tube d'acier Ø 33 mm, profilé et aplati de manière à former un ovale à l'extrémité. Finition de couleur noire (N), chromée (CR), blanc (BI10) ou couleur gris aluminium (VA), patins réglable.

Q-44 FIX

 COLORI POLIPROPILENE  | POLYPROPYLENE COLOURS | COULEURS DU POLYPROPYLÈNE

 **CL1 - GREEN CL2 (IT):** Si intende versione ignifuga a stock. Per altri colori in Classe 1 o GREEN Classe 2, ordine minimo 100 pz. per colore.
 Fire retardant version available in stock. For other colours in Class 1 or GREEN Classe 2, 100 pieces per colour minimum as order is required.
 C'est la version ignifuge disponible en stock. Pour d'autres couleurs Classe 1 ou GREEN Classe 2, commande minimum de 100 pièces par couleur.

FAGGIO | BEECHWOOD | HÊTRE



F
 faggio naturale
 natural color
 couleur naturelle



FB
 faggio sbiancato
 bleached color
 hêtre blanchi

 **FF: Costo aggiuntivo** per versione con trattamento ignifugo in **Classe 1**, la certificazione è disponibile solo per una superficie pari a circa **50 sedie**. **ATTENZIONE:** il faggio trattato con vernice ignifuga può subire un ingiallimento nel tempo quando esposto alla luce naturale.

FF: Additional cost for the Class 1 fire retardant certificate is available only for a surface corresponding approximately to 50 chairs. ATTENTION: the fire retardant treatment on the beechwood seats can become yellow when the chair is exposed to natural light.

FF: Coût supplémentaire pour version avec traitement ignifuge **Classe 1**, le certificat n'est disponible que pour une superficie égale à environ **50 chaises**. **ATTENTION: le hêtre traité avec vernis ignifuge a tendance à jaunir lorsqu'il est exposé à la lumière naturelle.**

FINITURA GAMBE | LEGS FINISHING | FINITION JAMBAGES



N
 nero
 black
 noir



CR*
 cromato
 chromed
 chromé



VA
 grigio alluminio
 aluminium grey
 gris aluminium



BI10
 bianco
 white
 blanc

* Abbinato alla struttura nera della seduta.
 Combined to the black frame of the seat.
 Assorti à la structure noire du siège.

FINITURA STRUTTURA | FRAME FINISHING | FINITION STRUCTURE



N
 nero
 black
 noir



VA
 grigio alluminio
 grey colour
 gris aluminium



BI10*
 bianco
 white
 blanc

*BI10 su richiesta (minimo 50 pezzi)
 BI10 on request (minimum 50 pieces)
 BI10 sur demande (minimum 50 pièces)

IMBOTTITURA | PADDING | REMBOURRAGE

DESCRIZIONE DESCRIPTION DESCRIPTION	DENSITÀ DENSITY DENSITÉ	SPESSORE THICKNESS ÉPAISSEUR
Q-44 FIX SEDILE Q-44 FIX SEAT Q-44 FIX ASSISE	50 Kg/m ³	1,5 cm
Q-44 FIX SCHIENALE Q-44 FIX BACKREST Q-44 FIX DOSSIER	50 Kg/m ³	0,5 + 1 cm